

# DRY CHEMICAL TANK UNIT

Proper Dry Chemical Tank unit should be selected from the specifications best fit to the installation site.

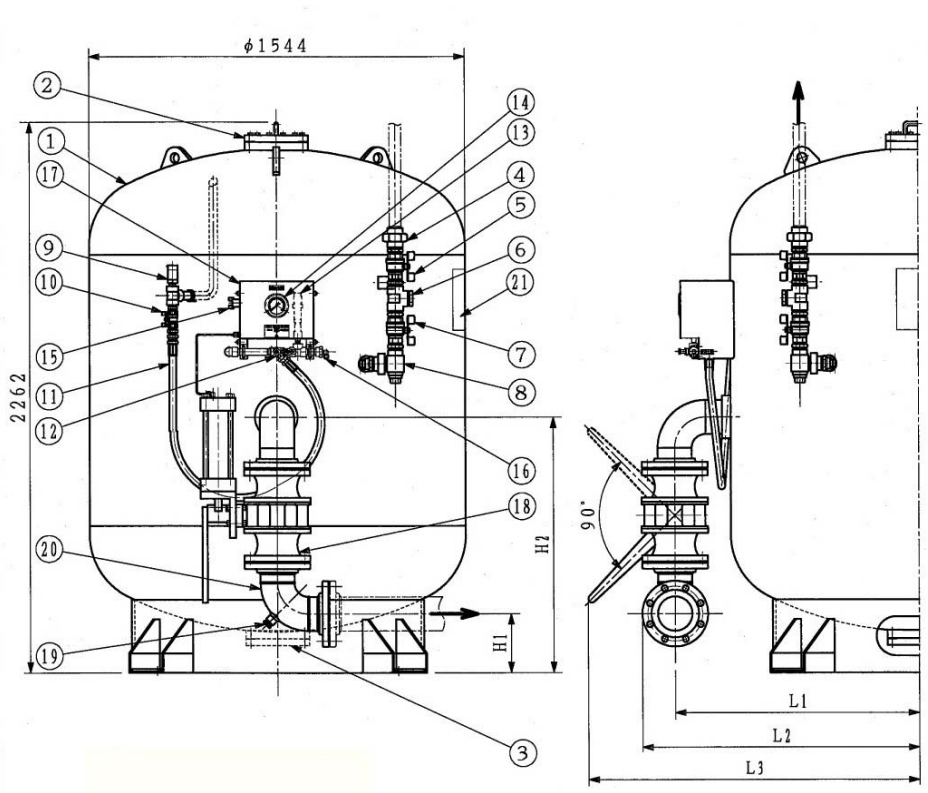

## Models YD□-1000~5000



No.	Parts Name
1	Tank Body
2	Filling Cap
3	Drain Cap
4	Union
5	Cleaning Valve
6	Connecting Cleaning Valve (1)
7	Tank Valve
8	Non Return Valve
9	Safety Valve
10	Outlet Internal Pressure Valve
11	Tank Connection Hose
12	Exhaust Valve
13	Differential of Constant Pressure
14	Pressure Gauge
15	Recovery Valve
16	Test Valve
17	Operation Panel
18	Outlet Valve
19	Connecting Cleaning Valve (2)
20	Elbow
21	Name Plate

Model	350	500	750	1000	1200	1500	2000	2500	3000	3500	4000	4500	5000	6000
Unit Height (mm)	1,350	1,350	1,600	—	—	—	—	—	—	—	—	—	—	—
Unit Width (mm)	880	880	1,240	1,140	1,140	1,235	1,335	1,385	1,645	1,750	1,845	1,845	2,000	2,000
Tank Height (mm)	1,150	1,450	1,560	1,400	1,610	1,780	1,840	1,800	1,885	1,835	1,885	2,050	2,000	2,262
Tank Diameter (mm)	512	512	618	824	824	874	974	1,124	1,228	1,328	1,432	1,432	1,532	1,544
Tank Volume (lit)	163	223	340	502	607	758	1,005	1,250	1,523	1,750	2,005	2,250	2,500	3,000
Unit Weight (kg)	184	214	342	550	550	670	830	1,050	1,300	1,400	1,650	1,800	1,950	2,100

Customer ordered alternation in material, special material, specifications, etc. shall be welcome.

Any capacity other than listed is available. spherical Tank (YD-Q Series) are also available.

List weight refers to the weight of Tank (Weight of agent not included)